

SCHEDULE OF RECOMMENDED FOUNDATION PIER MIN. SIZES

		MIN. FOUNDATION SIZES												Unknown Fill / Organics
		Bedrock			Gravel			Sand			Clay			
		Friction Angle, $\phi = 40^\circ$ (min) Cohesion, $c = 10,000$ psf (min)			Friction Angle, $\phi = 35^\circ$ (min) Cohesion, $c = 0$ psf (min)			Friction Angle, $\phi = 30^\circ$ (min) Cohesion, $c = 0$ psf (min)			Friction Angle, $\phi = 0^\circ$ (min) Cohesion, $c = 1000$ psf (min)			
		Bearing = 3000 psf			Bearing = 2000 psf			Bearing = 2000 psf			Bearing = 1500 psf			
		Total Density $\gamma = 130$ pcf (min)			Total Density $\gamma = 120$ pcf (min)			Total Density $\gamma = 115$ pcf (min)			Total Density $\gamma = 110$ pcf (min)			
Exposure	Wind Speed (mph)	Pier Diameter (in)	Pier Depth (in)	Pier Steel	Pier Diameter (in)	Pier Depth (in)	Pier Steel	Pier Diameter (in)	Pier Depth (in)	Pier Steel	Pier Diameter (in)	Pier Depth (in)	Pier Steel	
		B	110	24	30	4-#5	24	30	4-#5	24	30	4-#5	24	30
	130	24	30	4-#5	24	36	4-#5	24	36	4-#5	24	30	4-#5	
	140	24	30	4-#5	24	42	4-#5	24	42	4-#5	24	30	4-#5	
C	110	24	30	4-#5	24	36	4-#5	24	42	4-#5	24	30	4-#5	
	130	24	30	4-#5	24	42	4-#5	24	48	4-#5	24	36	4-#5	
	140	24	30	4-#5	24	48	4-#5	24	54	4-#5	24	36	4-#5	

Note: Foundation pier minimum depth shall exceed depth required locally for frost protection.

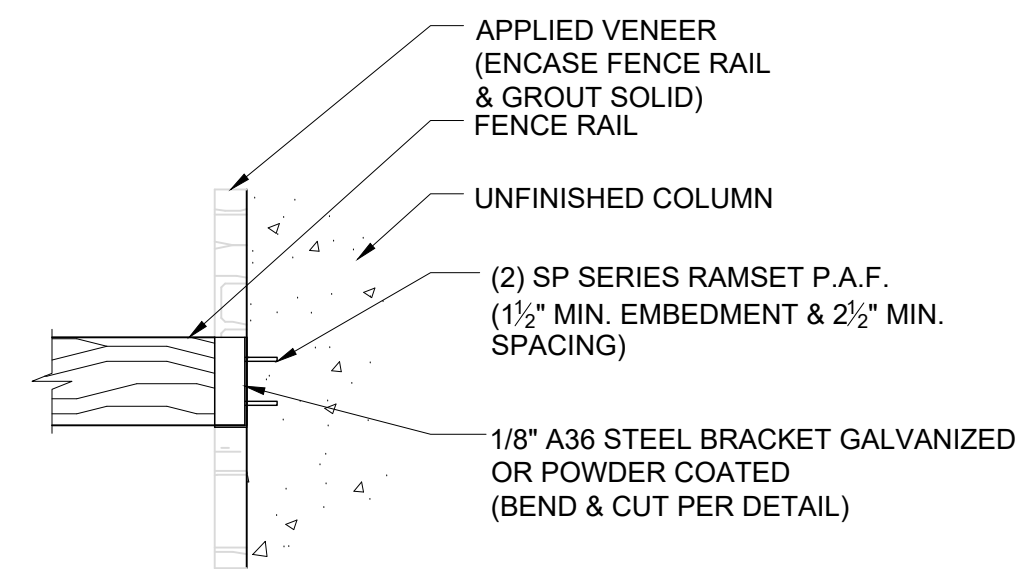
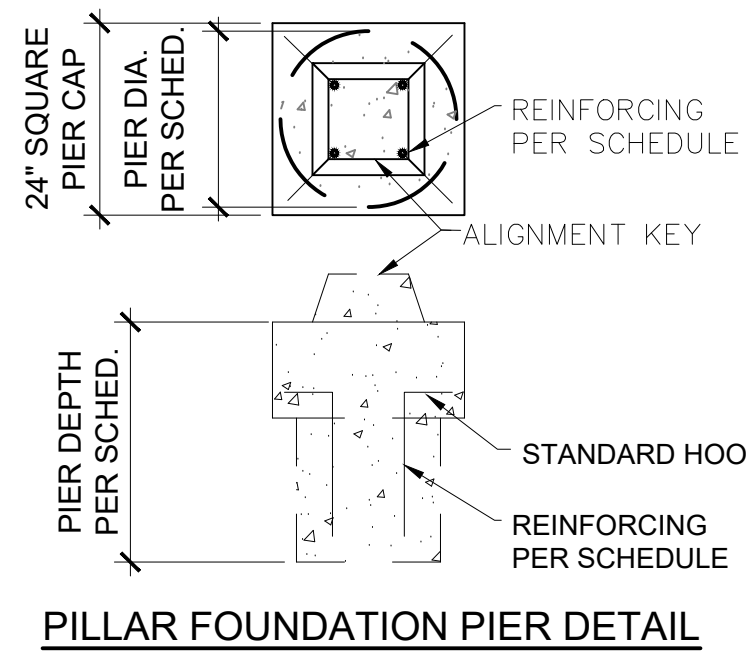
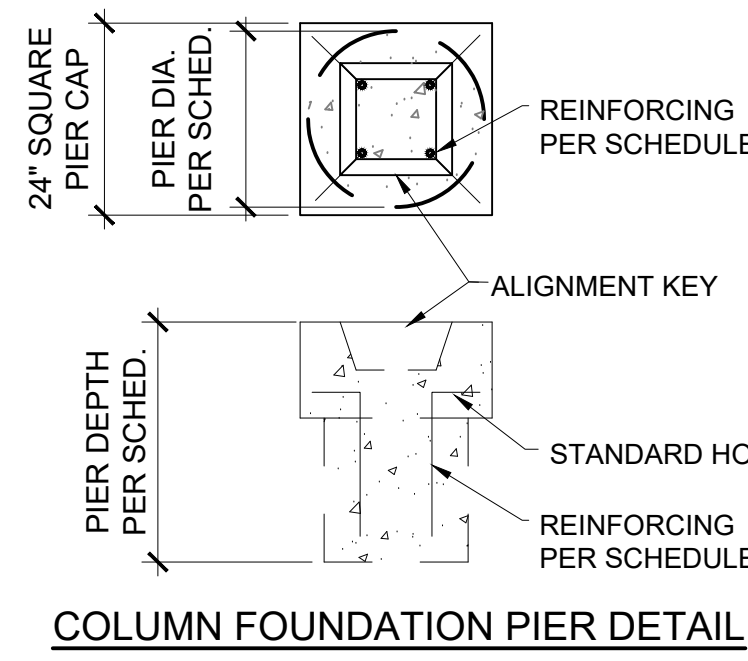

SPLIT RAIL TO UNFINISHED COLUMN CONNECTION

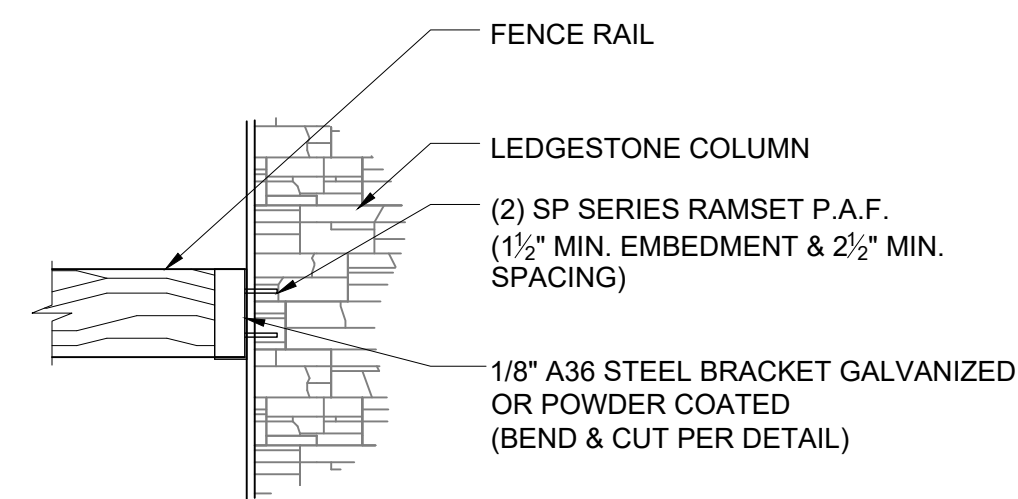

SPLIT RAIL TO LEDGESTONE COLUMN CONNECTION

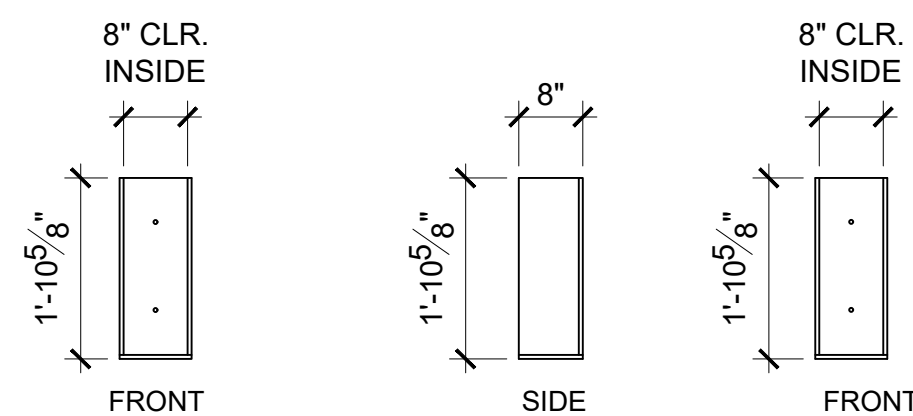

NOTE: ALL STEEL TO BE 1/4" THICK A36  
ALL WELDS TO BE 1/8" FILLET WELD  
ALL AROUND ALL PLATES.

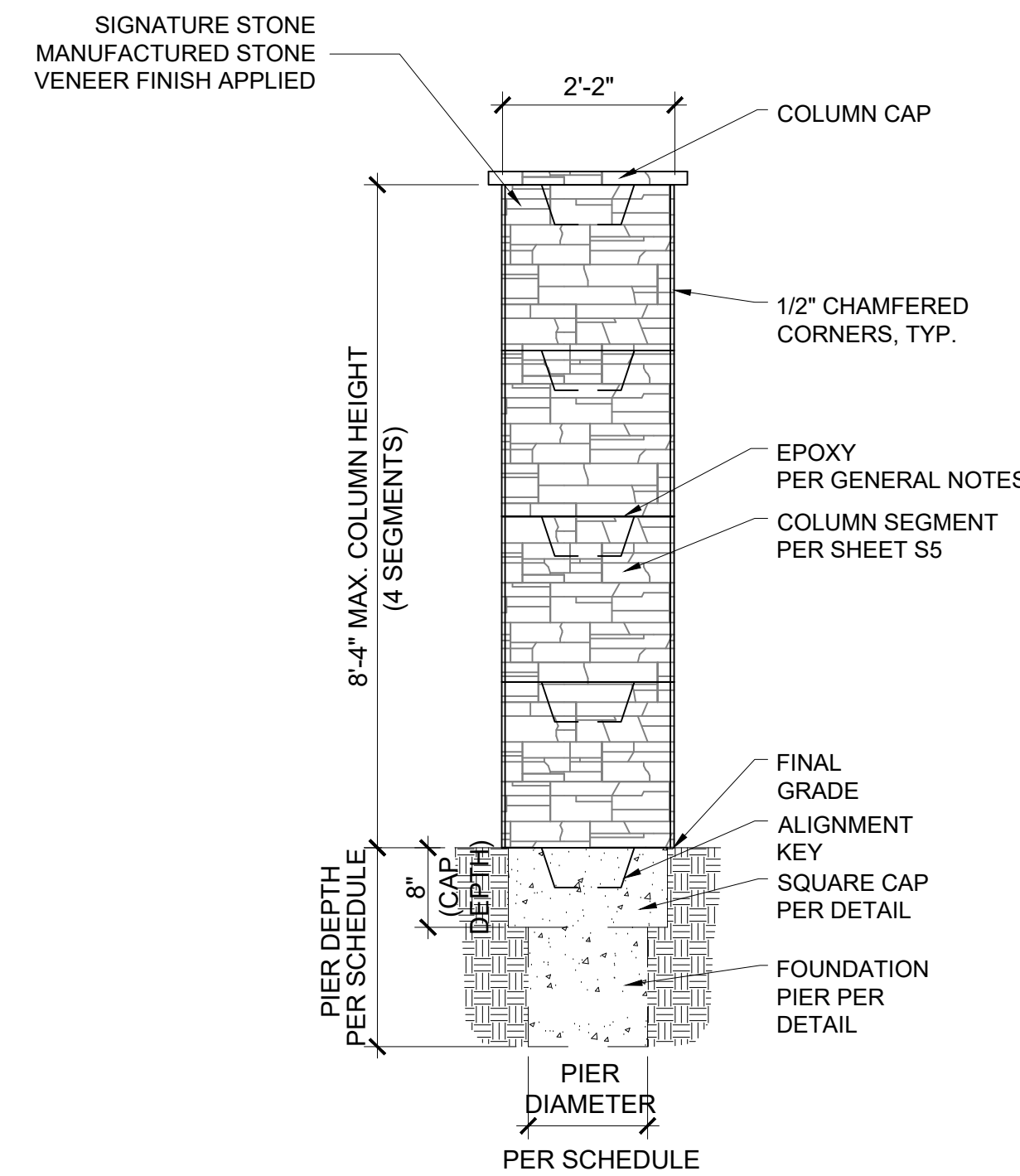

LEDGESTONE COLUMN (FREE STANDING) ELEVATION

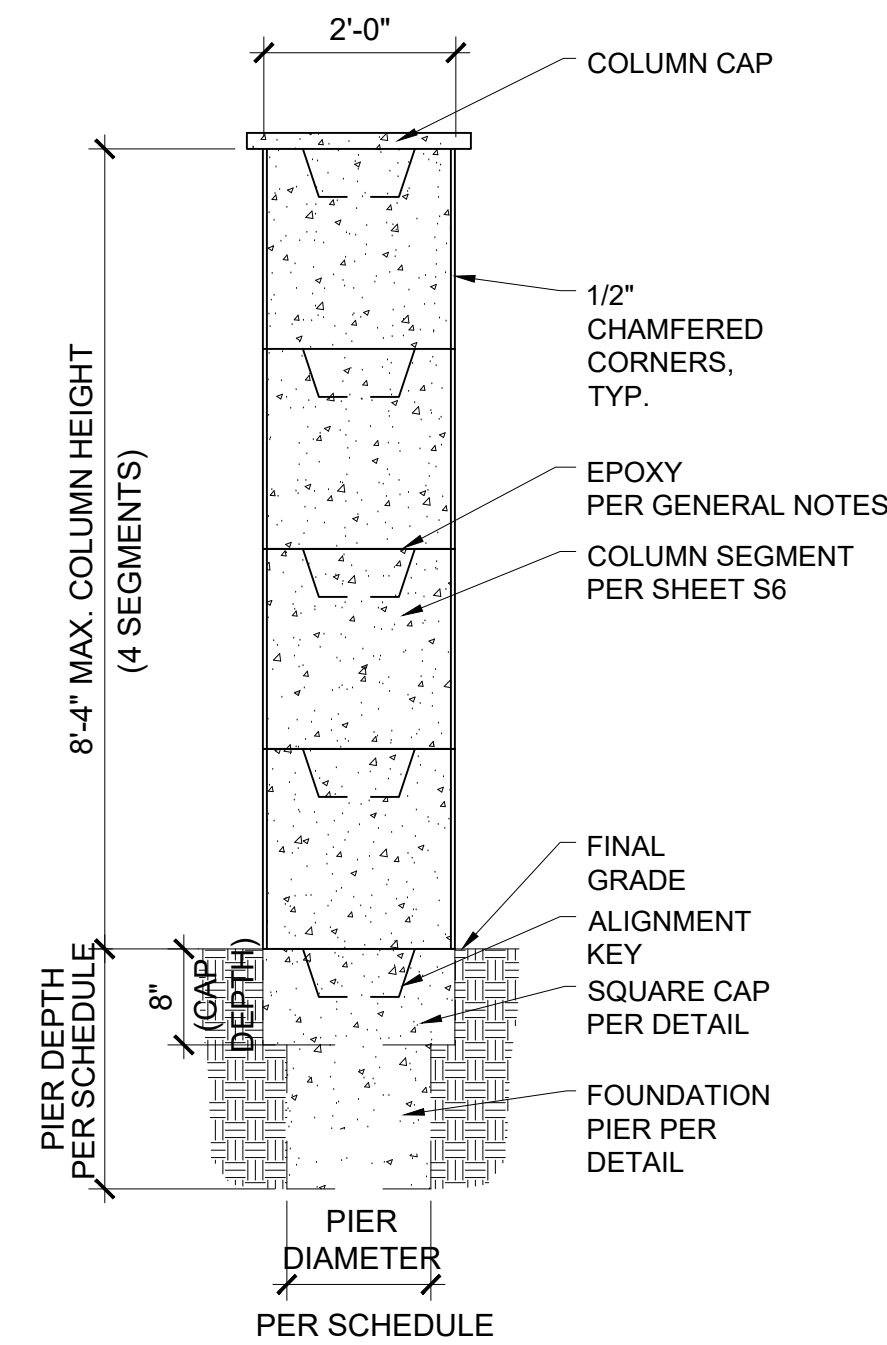

UNFINISHED COLUMN (FREE STANDING) ELEVATION

NOTE: FREE STANDING LEDGESTONE AND UNFINISHED COLUMNS WITH HEIGHTS GREATER THAN THOSE SHOWN SHALL BE EVALUATED AND HAVE A FOUNDATION DESIGNED BY A LICENSED PROFESSIONAL ENGINEER.

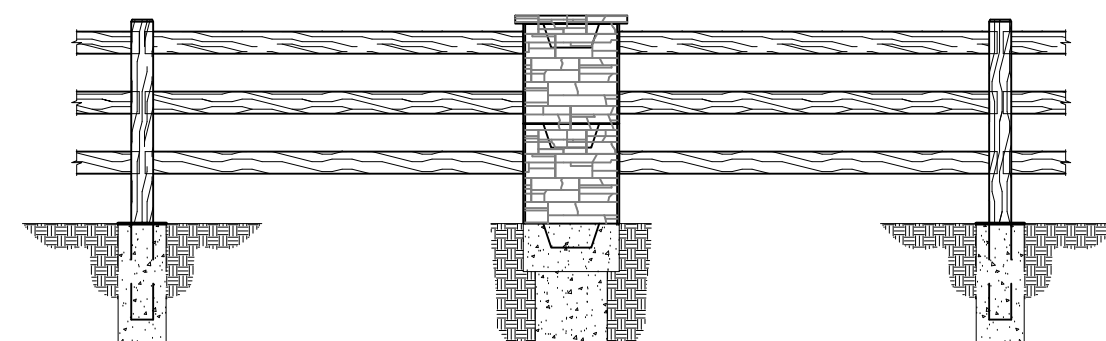

LEDGESTONE COLUMN W/ (3 RAIL) SPLIT RAIL FENCE

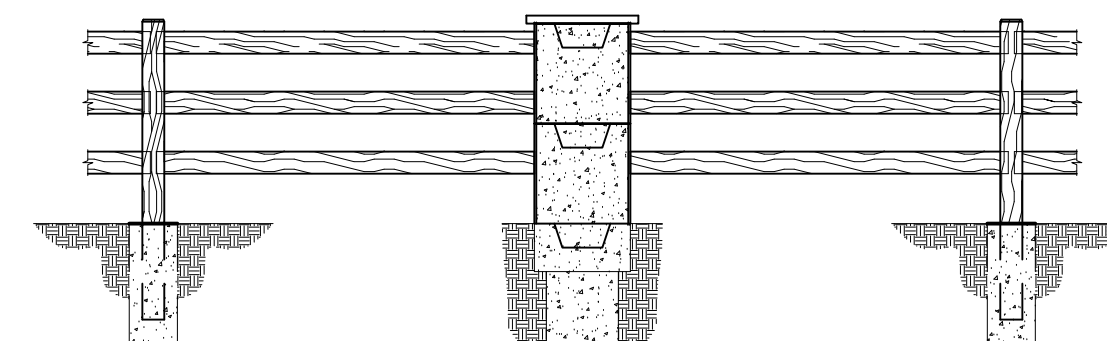

UNFINISHED COLUMN W/ (3 RAIL) SPLIT RAIL FENCE

SPECIFICATION DATA

- PRODUCT NAMES:**  
SPLIT RAIL FENCE
- MANUFACTURER:**  
SIGNATURE STONE, LLC.  
211 30TH STREET  
GREELEY, CO 80631
- PRODUCTS DESCRIPTION:**  
PRODUCTS ARE INTENDED FOR RESIDENTIAL, COMMERCIAL, AND INDUSTRIAL EXTERIOR FENCING, SCREENING WALLS AND NOISE BARRIERS.
- COMPOSITION AND MATERIALS:**  
A MIX OF HIGH STRENGTH PORTLAND CEMENT CONCRETE W/ FIBER MESH REINFORCING, MEETING OR EXCEEDING THE REQUIREMENTS OF ASTM-C150, NATURAL AGGREGATES, AND IRON OXIDE COLORS PLACED AND CAST WITHIN FACTORY MOLDS. FILLED MOLDS ARE VIBRATED AFTER SETUP OF MIX, CURED, AND PACKAGED FOR SHIPMENT.
- SIZES:**  
FENCE POSTS ARE TYPICALLY PLACED AT 60.0 in. CENTERS WITH THE FENCE PANELS BEING 12.0 in. IN HEIGHT AND APPROXIMATELY 2.0 in. IN THICKNESS. HEIGHT OF THE FENCE SYSTEM SHOULD NOT EXCEED THAT SHOWN. CONTACT MANUFACTURER FOR ENGINEERING NOT INCLUDED IN THESE SPECIFICATIONS.
- LIMITATIONS:**  
FENCE SYSTEM IS DESIGNED FOR TYPICAL CONDITIONS AND APPLICATIONS. SIGNATURE STONE RECOMMENDS FENCE SYSTEM APPLICATION AND FOUNDATION INSTALLATION BE APPROVED BY LOCAL PROFESSIONAL ENGINEER ON EVERY PROJECT. FENCE SYSTEM SHOULD NOT BE USED AS AN EARTH RETENTION SYSTEM UNLESS MODIFICATIONS IN DESIGN AND CONSTRUCTION ARE DONE BY A REGISTERED PROFESSIONAL ENGINEER AND APPROVED BY THE MANUFACTURER.
- TECHNICAL DATA FOR CONCRETE MIX:**  
PRE-CAST FENCE POSTS AND PANELS:  
MIN. 28 DAY COMPRESSIVE STRENGTH = 5,000 psi  
CAST-IN-PLACE FOUNDATION PIERS:  
MIN. 28 DAY COMPRESSIVE STRENGTH = 3,000 psi
- BUILDING CODES:**  
DESIGN OF FENCE POSTS, PANELS AND FOUNDATION PIERS IS BASED ON 2015 VERSION OF IBC, ACI, AND AASHTO CODES.
- INSTALLATION:**  
THE POSTS ARE POSITIONED AND WET-SET INTO A DRILLED CONCRETE FOUNDATION PIER. THE PIER SIZE, DEPTH AND REINFORCEMENT SHALL BE AS SPECIFIED BY LOCAL ENGINEER OR AS SHOWN ON SCHEDULE. AFTER POSTS AND RAILS ARE ACCURATELY SPACED, PLUMBED AND LEVELLED, THEY ARE BRACED UNTIL PIER CONCRETE HAS OBTAINED ITS INITIAL STRENGTH.
- DRAINAGE:**  
THE LONG-TERM PERFORMANCE OF ALL FOUNDATIONS, INCLUDING THE SIGNATURE STONE FENCE FOUNDATION, DEPENDS ON PROPER GRADING. POSITIVE DRAINAGE AWAY FROM THE FENCE FOUNDATIONS TO THE EXTENT POSSIBLE IS RECOMMENDED AT ALL TIMES. PANELS CAN BE ARRANGED TO ALLOW FOR CONTINUOUS OR INTERMITTENT DRAINAGE BENEATH THE FENCE WHERE NECESSARY.

GENERAL NOTES:

- ALL CONSTRUCTION TO MEET LOCAL CODES AND AMENDMENTS
- ALL CONCRETE FOOTINGS SHALL USE TYPE III CEMENT.
- ALL REINFORCING STEEL SHALL CONFORM TO ASTM A 615, GRADE 60 (GRADE 40 FOR #3 REBAR ONLY).
- ALL PIER FOUNDATIONS ARE TO BE LOCATED IN UNDISTURBED SOIL, UNLESS APPROVED BY A GEOTECHNICAL ENGINEER.
- FENCE WALL PANEL STANDARD DESIGN IS FOR A WIND LOAD OF 140 MPH (ULTIMATE). WIND PRESSURE IS BASED ON IBC WIND PRESSURES.
- APPROVAL OF THE ENGINEER IS REQUIRED WHEN FENCE IS USED UNDER A CONDITION WHERE THE SPECIFICATIONS ARE DIFFERENT THAN SHOWN.
- THE CONTRACTOR SHALL VERIFY ALL CONDITIONS AT THE JOB SITE.
- THE POSTS, PANELS AND CAPS ARE MADE OF CONCRETE AND ARE MANUFACTURED BY A NATIONAL READY MIX CONCRETE ASSOCIATION APPROVED MANUFACTURER.
- A FULLY DIMENSIONED PLOT PLAN IS REQUIRED FOR A BUILDING PERMIT AND MUST BE PROVIDED WITH EACH STANDARD PLAN.
- LOCATION AND FENCE HEIGHT SHALL COMPLY WITH CITY/COUNTY FENCING CODES AND CURRENT CONDITIONS.
- ALL WORK SHALL COMPLY WITH CITY/COUNTY GRADING ORDINANCES.
- EPOXY SHALL BE SIKAFLEX-1a (175 PSI TENSILE STRENGTH) OR APPROVED EQUIVALENT. CONTRACTOR SHALL USE EPOXY ON ALL ADJOINING SURFACES OF COLUMN SEGMENTS.

SPLIT-RAIL FENCE SYSTEM

NOTE: ALL DIMENSIONS SHOWN ON THIS SHEET ARE FOR INFORMATION PURPOSES ONLY. ACTUAL DIMENSIONS MAY VARY DUE TO MANUFACTURING AND MOLDING TOLERANCES.

**CTL THOMPSON**  
INCORPORATED  
P.O. BOX 8465  
FORT COLLINS, CO 80524  
www.cdt.com

THESE DIMENSIONS AND ACCOMPANYING NOTES ARE THE PROPERTY OF SIGNATURE STONE, LLC. ANY REPRODUCTION OR USE OF THESE DIMENSIONS OR NOTES WITHOUT THE WRITTEN PERMISSION OF SIGNATURE STONE, LLC IS PROHIBITED. ALL RIGHTS RESERVED.

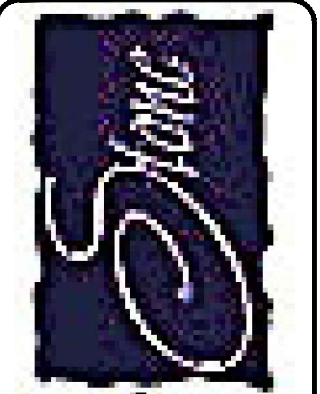

Signature Stone

2-3 RAIL FENCE

REV.	DATE	REVISION/ISSUE
1		
2		
3		

**CLIENT:**  
SIGNATURE STONE  
211 30TH STREET  
GREELEY, COLORADO, 80631  
contact: ERIC BOEHNER  
(970) 351-0270

TDM	
DES	S8
FC07305.000	
01/10/2020	
PER PLAN	